

DISTRIBUTED CONTROL SYSTEM EMULATION FOR THE BERGEN RE-POWERING PROJECT TRAINING SIMULATOR.

C. A. Jones, C. McKim, W. T. Sneed, R. B. Brownell, S. S. Godbole, and G. F. Malan
Framatome Technologies
Lynchburg, Virginia 24506-0935

J. Witkowski
Public Service Electric & Gas
Newark, New Jersey 07657

Key Words

Real-time simulation, Trainers, Energy, Control Systems

Abstract

A compact simulator will be used by Public Service Electric and Gas to support a systematic program for training operators in the safe and efficient operation of the re-powered Bergen generating station. The unit is controlled by a combination of a Honeywell TDC-3000 Distributed Control System (DCS), a Westinghouse WDPF DCS, and hard panel controls.

The design and implementation of the control system emulations, both for the control logic and the man machine interface (MMI) are discussed. The collection of the necessary data; creation of the control logic source code; creation of the MMI source code, touch-screen emulation, and custom keyboard emulation; and integration of the dissimilar DCS systems and hard panels are reviewed.

Introduction

The Bergen Generating Station is currently being converted from a coal-fired conventional steam plant to a combined-cycle plant. The re-powered station consists of four combustion turbine/generator sets, each exhausting into its own heat recovery steam generator. Each combustion turbine/generator (CT/G) produces approximately 100 megawatts, for a combined capacity of 400 megawatts, using natural gas as the primary fuel and kerosene as the alternative fuel. Steam from the four, heat-recovery steam generators is supplied to an existing cross compound steam turbine/generator (ST/G)

for an additional 200 or more megawatts, for a unit total of 600 megawatts.

The unit is controlled by Honeywell TDC 3000 and Westinghouse WDPF hardware from the control room. A section of hard panel controls containing indicator lights and switches are part of the Westinghouse DCS control logic. The Westinghouse control system controls the steam turbine, while the Honeywell control system provides the necessary operator interface with the gas turbines/generators and balance-of-plant to allow for startup, shutdown and on-line load maneuvering.

For the simulator, Public Service Electric and Gas evaluated the benefits of both a fully emulated DCS and a partially stimulated DCS system. In the latter, a DCS vendor's MMI is interfaced directly with the process and control models. Public Service Electric and Gas selected an emulated system recognizing the significant initial cost savings and the low cost for future expansion with additional emulated MMI workstations.

The Bergen compact simulator specification required that the emulated MMI displays and control system could be quickly and easily updated by simply retranslating the DCS files. This capability has not been available in prior compact simulator projects without significant rework each time the DCS files are retranslated. The objective of this criteria was to keep the simulator up-to-date with anticipated plant changes, particularly valuable for the initial start-up phase of a re-powered plant.

The compact simulator configuration is detailed in Figure 1. The Framatome Technologies' compact simulators all utilize the same basic configuration. Simulation is supported by an Intel-based Symmetric Multi-Processor (SMP) computer running Microsoft Windows NT 3.5. The SMP machine can use from one to four Pentium processors. All other machines are single-processor,

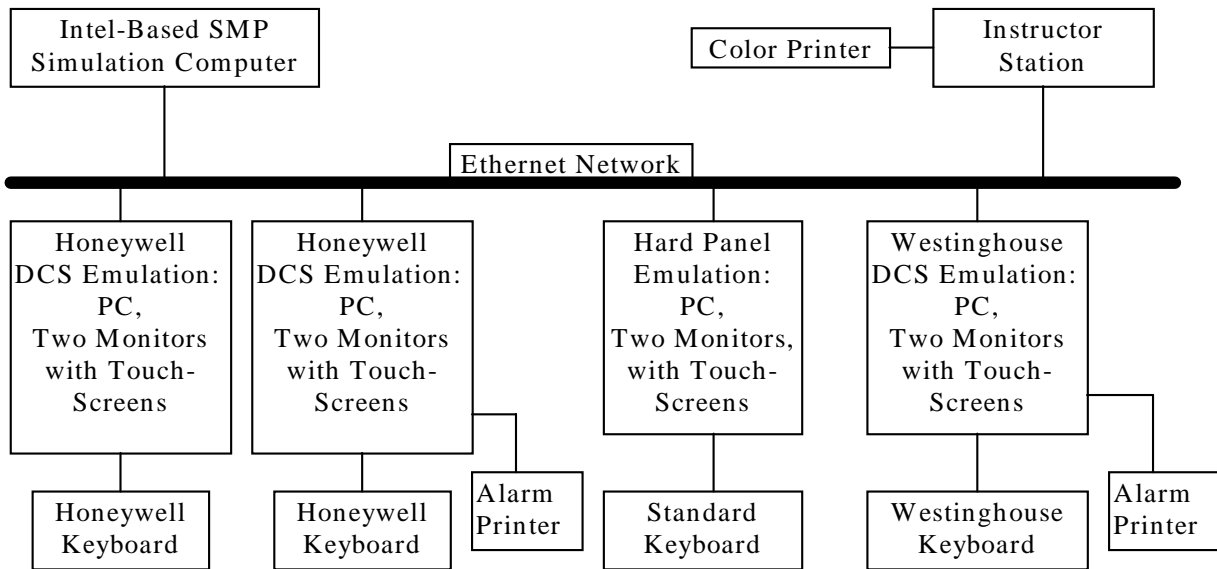

Figure 1. Configuration of Bergen Compact Simulator

Intel-based machines running Windows or Window NT. Data transfer between machines occurs over an ethernet network using the TCP/IP protocol.

The process model for the Bergen compact simulator incorporates the control logic and all physical models (i.e., pipes, pumps, turbines). Creating a physical-process model from plant drawings and component data is a complex task. Although it is possible to write a custom program to simulate a plant, the use of a component-oriented modeling library is more efficient and allows for the reuse of well-tested code. Framatome Technologies compact simulators use the Modular Modeling System - Real Time Capable (MMS-RTC) component library. MMS-RTC makes use of the Advanced Continuous Simulation Language (ACSL) from Mitchell and Gauthier Associates (MGA, 1991). The simulation source code is an ACSL source code with calls to pre-defined ACSL macros from the MMS-RTC library. Physical process model source code generation is greatly aided by the use of a graphical program known as the MMS Model Builder. In plants where a DCS is not used, the MMS Model Builder can be used to model the plant controls as well.

Control Logic Emulation

A critical requirement of any power plant simulation is the accurate representation of the control system. Framatome Technologies has developed a Windows™

based control logic and MMI translator, MMS DCS Translator. This program is used to convert the DCS system configuration data directly into source code that is merged with the source for the physical-component process model.

The Honeywell DCS data files were translated using the MMS DCS Translator. After the translator is started, a DCS "personality" is loaded to translate the particular type of input desired. In this way, the user has a common interface from which to work. Input to the translator for the Honeywell control logic translator is the *.EB (Exception Build) files. Data from the *.EB files is converted directly into ACSL source code. The Honeywell Advance Processor Module (APM) architecture, including the slot information, is recreated into a single ACSL source code.

The MMS DCS Translator is designed to be completely automatic and requires no manual intervention unless the control logic files, *.EB files, are incomplete and require supplemental control logic for reasonable plant control. The MMS DCS Translator was used to process the Honeywell control logic files for over 4250 digital and analog control entities (e.g. specific plant control and interlock functions). All nine of the Honeywell Advanced Processor Modules (APMs) used in the Bergen plant were simulated and these APMs supported the following processes:

- Four trains of combustion turbines/generators and heat recovery steam generators controls and interfaces in conjunction with the high and low pressure steam distribution systems
- Condensate and feedwater control and demineralized water supply
- Electrical auxiliaries
- Electrical switch gear
- Cooling water system
- Fuel/gas supply

The control functions simulated include:

- Analog and digital input and output
- PID controllers with lead/lag, tracking, and smooth transfer
- Composite device controllers with interlocks and permissives
- Digital logic (pulsed/latched)
- Multiple mode switches
- Position proportional
- High/low/average
- Middle of three, totalizer, general piecewise linear functions, etc.

Westinghouse source listings for the Distributed Processing Unit (DPU) control logic files are converted to ACSL source code by the EPRI Westinghouse control logic translator. Although the EPRI translator produces ACSL code, some manual changes were required for compatibility with the Framatome Technologies simulator. The functions of four DPUs are simulated and they control the response of the steam turbine/generator.

Variable names used in the physical process model were carefully tracked to simplify the merging of the three source codes (physical process, Honeywell control logic, and Westinghouse control logic). The ACSL translator uses the merged code to create a single FORTRAN source code of the simulation. The object file from this compilation is linked with the MMS-RTC runtime library to create the final executable.

MMI Interface Emulation

Framatome Technologies has developed MMI interface personalities for the MMS DCS Translator for both the

Honeywell TDC 3000 and the Westinghouse WDPF systems. The output of the translators is source code and project files for Microsoft Visual Basic. A Visual Basic executable is built for every screen for which source code is available. Examples of the Visual Basic screens are shown in Figures 2. through 5. The communication methods, touch-screen interface, and custom keyboard setup are discussed under the section on runtime configurations.

The Westinghouse translator uses the *.GCC files for the information necessary to build the graphical screen. Two other utility programs have been developed to provide supplemental information to further automate the process. One of these programs reads the *.DPU files and determines the data types (DOUBLE PRECISION, INTEGER, LOGICAL) for the interface variables. This feature prevents any false assumptions about variable type in the MMI source-code generation. Text algorithms related to keyboard actions are also read. The other program reads the shape library file to create any custom user-defined shapes needed for the screens.

Keyboard support for the Westinghouse workstation is provided by use of a hardware emulation. The keyboard used is the EPRI generic keyboard. Framatome Technologies developed custom overlays for this keyboard, which reflect both the Westinghouse default configuration and customizations made for the Bergen station. Hardware interface to the EPRI generic keyboard is through one of the computer's serial ports.

Honeywell translation involves the processing of an ACSII dump of the binary *.DS files created by the Honeywell Picture Editor. All of the sub-picture and change-zone information is recovered from the files. Over 300 Honeywell screens were processed for the Bergen simulator. This processing is performed automatically with no manual touch-up necessary.

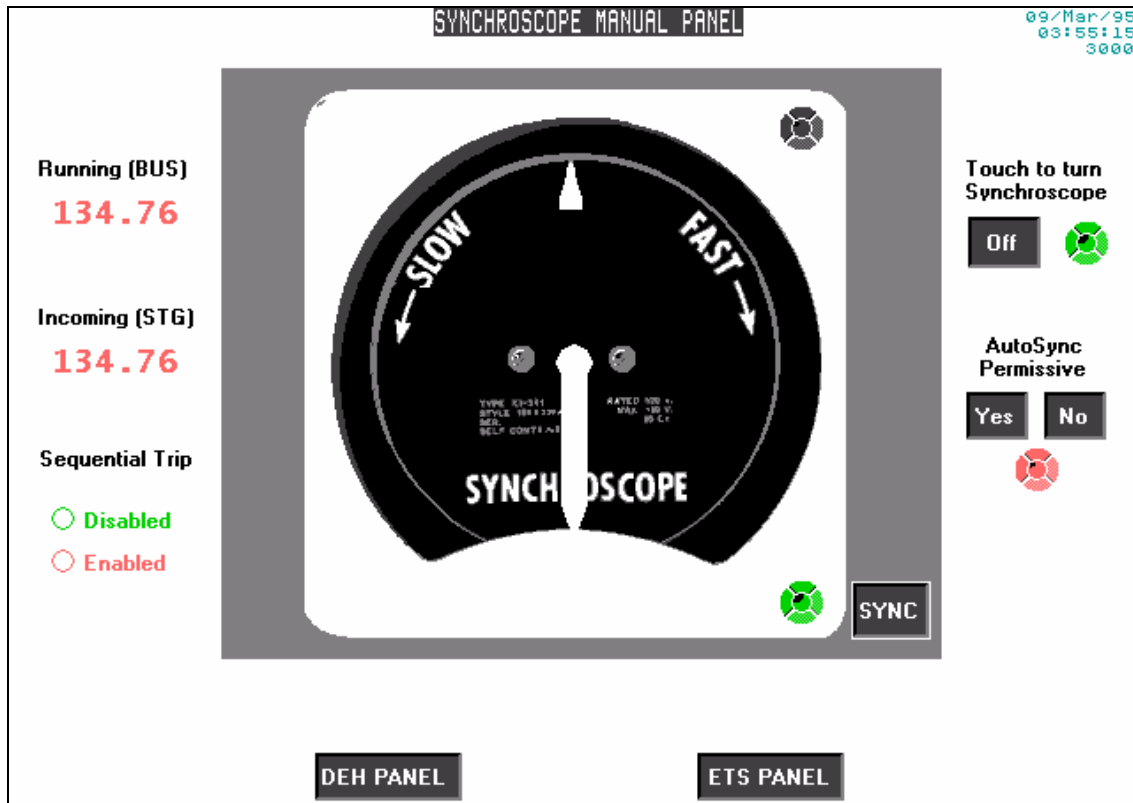

Figure 2. Emulated Hard Panel

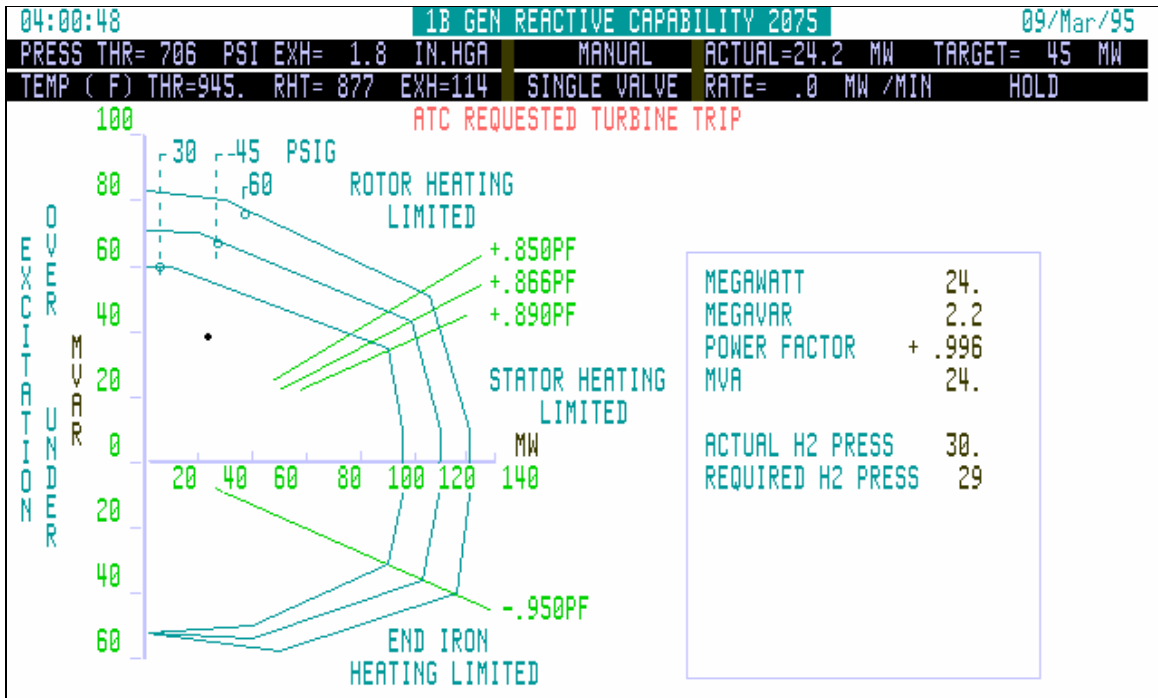

Figure 3. Westinghouse WDPF Screen for Generator.

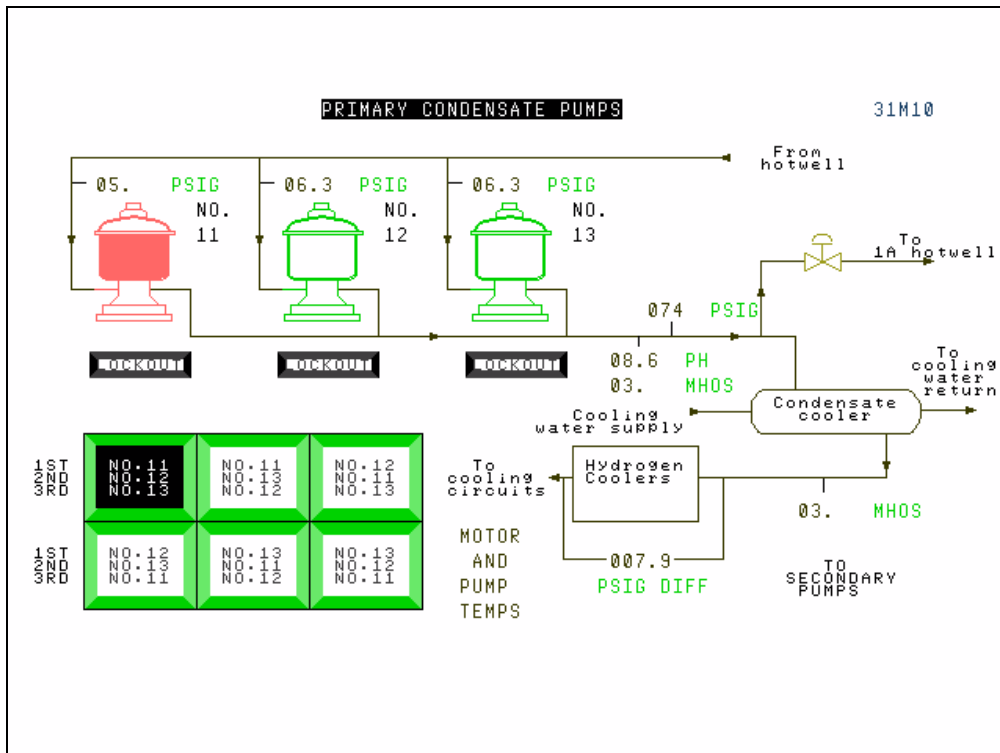

Figure 4. Honeywell TDC3000 Screen for Condensate Control

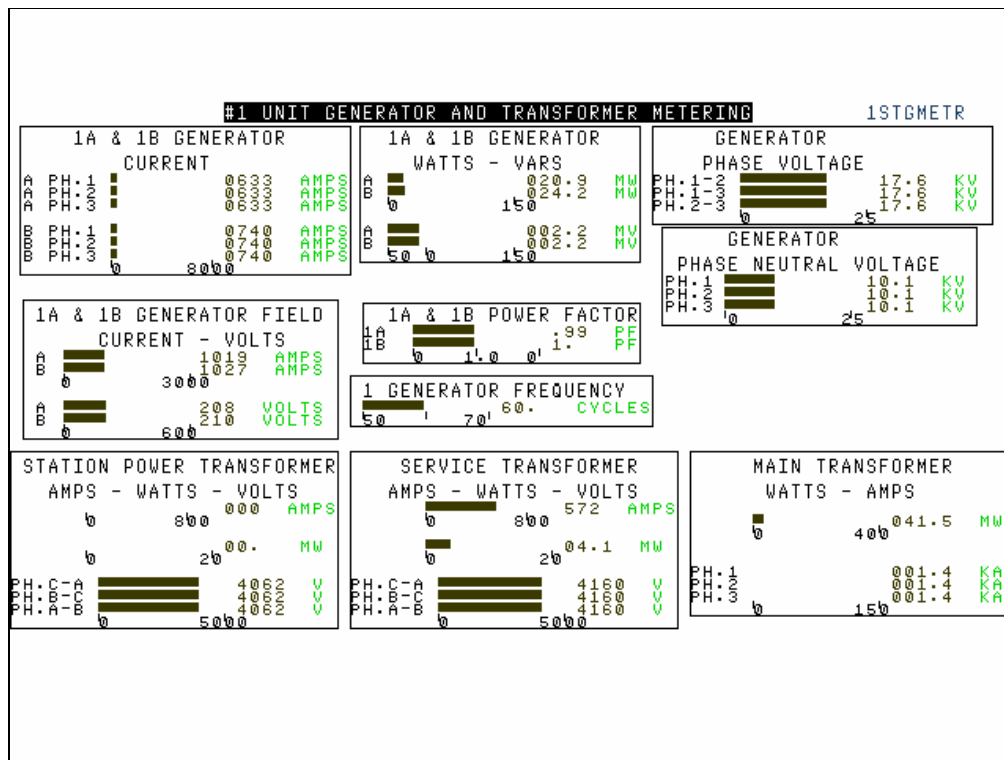

Figure 5. Honeywell TDC3000 Screen for Electrical System

Keyboard support of the Honeywell workstations is provided by the use of actual Honeywell keyboards. The primary reason for this step is the Honeywell keyboard contains LEDs on four rows of programmable keys along the top of the left side of the keyboard. The EPRI keyboard was not designed with this in mind. Hardware interface to the keyboard is through a 4-20 milliamp, current-loop interface card. This card appears as an additional serial port to the operating system.

Both the Honeywell TDC 3000 and Westinghouse WDPF personalities find and translate all hot-spot, variable tag name, and display control logic information. Any code in the files that changes attributes such as color, highlighting, and blinking at run-time is automatically converted to Visual Basic source code. Screen-specific information concerning the touch-screen configuration, tab-order, and color palette is converted to Visual Basic source code as well.

Runtime Configuration

Control and communication between the process model and the remote machines is provided by a program known as Simulation Master. Simulation Master runs on the same machine as the process model and supports any network configuration and protocol stack. TCP/IP is the current default protocol and either ethernet or Token-Ring can be supplied as the network.

A companion program that controls the MMI screens on each MMI workstation is known as the MMI Manager. As data is received from the process model the MMI Manager places the data in memory so that the MMI screens can be updated. Then the MMI Manager sends a message to all currently running MMI screens that an update is to occur.

The MMI Manager also contains all the interface code necessary for all of the touch-screen and custom keyboard interfaces. The function of this interface is roughly analogous to the function of a device driver.

Because Microsoft Windows™ is a message-passing operating system (events are placed into a queue for processing), some of the default actions of the system need to be modified or over-ridden. Most of these actions are related to the interaction of the operator with the touch screen. Each DCS has its own method of processing the touching (touch-down) and un-touching (lift-off) of the screen. Any changes to these actions can easily be handled by the MMI Manager. A configuration file is provided, using a standard Windows format, to control which DCS touch-screen and keyboard to use.

The MMS Instructor Station is provided with all of the Framatome Technologies simulations. Control of the simulation, introduction of malfunctions, and display of simulation values are all supported by the Instructor Station.

Conclusion

The compact simulator for the Bergen re-powering project involved the emulation of two dissimilar DCS control systems. Source code for the control system was produced using control logic translators. Over 340 MMI screens were generated using the Framatome Technologies MMI translators that automatically process the DCS vendor's graphics files with no manual work required for touch-up. The process model was developed using the MMS-RTC and MMS Model Builder. Full touch-screen support, emulated keyboard and dual-monitor support has been provided. These systems were integrated into Framatome Technologies compact simulator network to provide multi-processor support and a full featured instructor station.

References

Mitchell & Gauthier Associates Inc., 1991. *Advanced Continuous Simulation Language Reference Manual*.